



BYIBA
BACKLIGHT

025.373 (REV08)

MADE IN ITALY

GU10



GU10 MAX 5W
GU10 MAX 35W
GU10 MAX 20W
110-277V~ 50/60Hz

IP 20



GU4 MAX 20W 12V
GU5.3 MAX 35W 12V

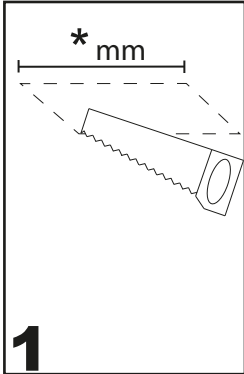

1

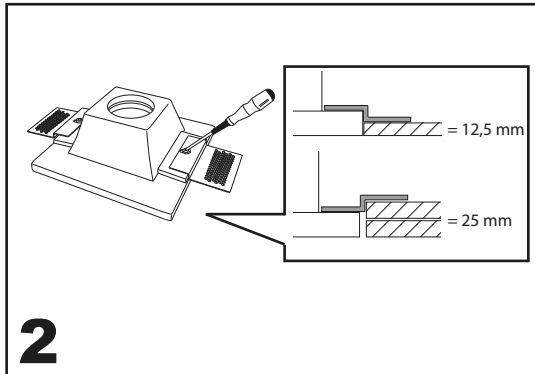

2

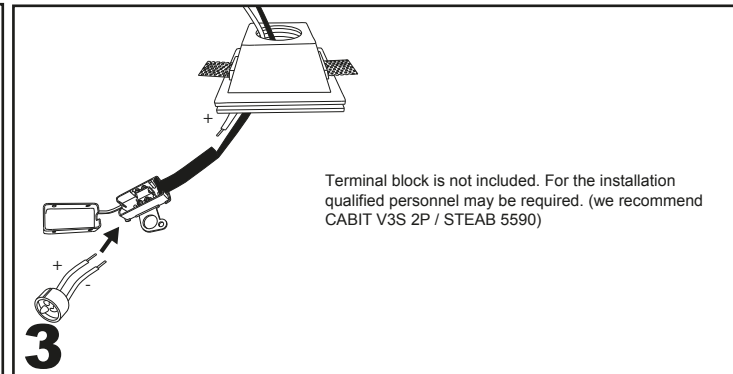

3

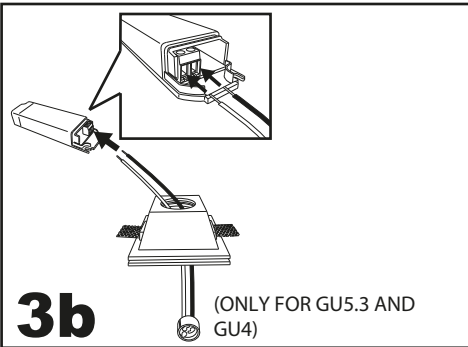

3b

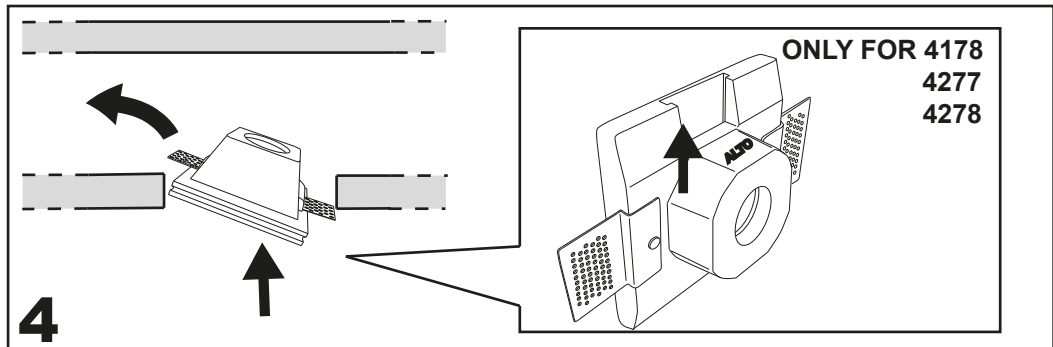

4

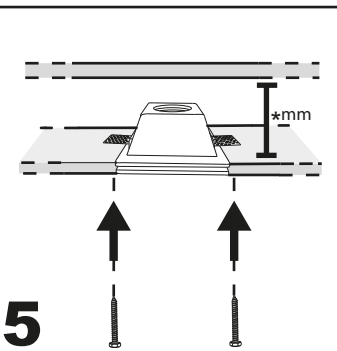

5

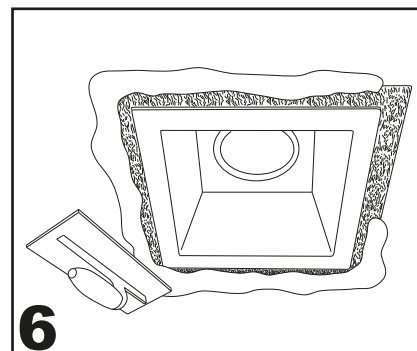

6

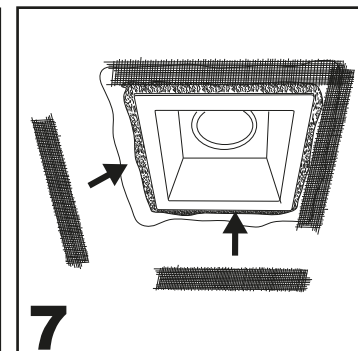

7

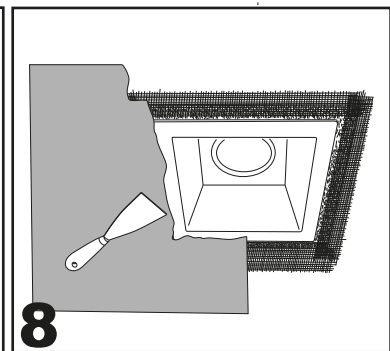

8

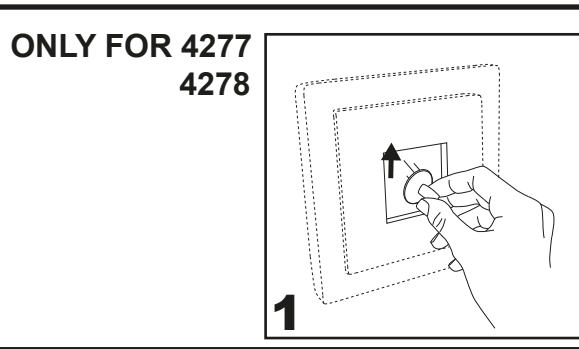

ONLY FOR 4277
4278

1

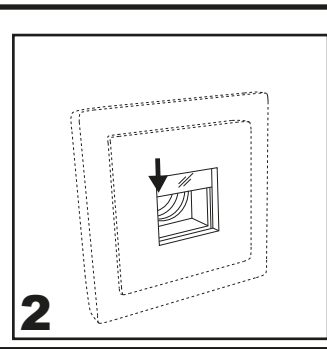

2

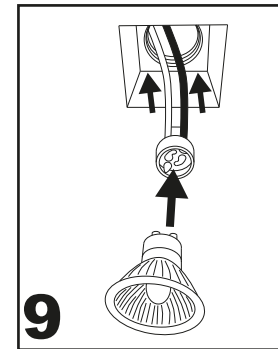

9

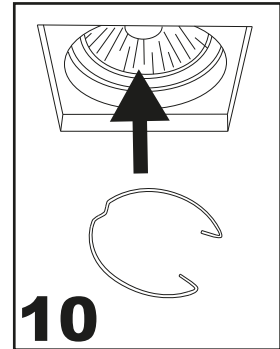

10

Art.		
2446	315 x 245	30
2417	110 x 365	80
4170	175 x 225	75
4174	155 x 155	130
4175	190 x 190	110
4176	125 x 125	85
4177	155 x 155	130
4178	155 x 155	115
4179	155 x 155	95
4180	155 x 155	110
4180A	235 x 155	115
4180B	295 x 155	115
4181	125 x 125	80
4183	185 x 185	125

Art.		
4184	165 x 195	35
4186	165 x 195	35
4199	125 x 160	65
4210	290 x 180	120
4215	205 x 205	95
4216	205 x 205	95
4275	125 x 125	80
4276	125 x 125	80
4277	125 x 125	80
4278	125 x 125	80
4280	125 x 125	80
4281	125 x 125	60
8919	200 x 200	75
8935G	245 x 245	30

Art.		
8935H	250 x 250	30
8935I	310 x 310	30
8935L	200 x 200	45
2446B	340 x 410	30

GLASS:

4177

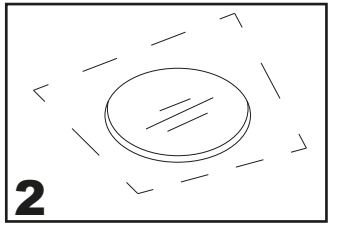
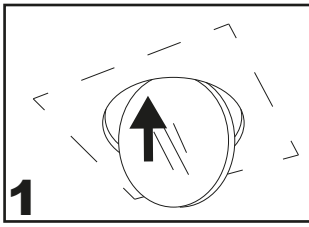

4178

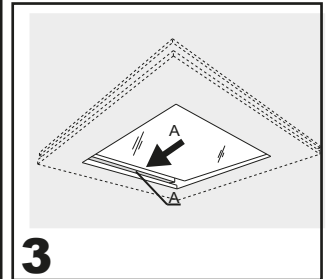
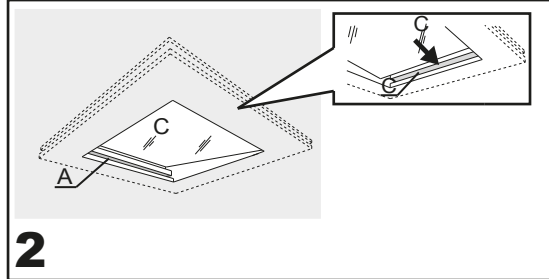
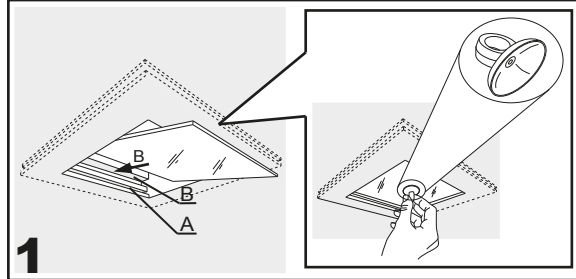

IMPORTANT

To ensure equipment safety you must carefully follow the instructions below. This leaflet must be kept handy by personnel entrusted with all ordinary and extraordinary maintenance.

- Before any installation or maintenance operation on the bulb, make sure it is disconnected from power.
- Fit the correct bulbs, according to the type and power indicated on the lamp data label.
- Make sure the lamp technical features are compatible with the use you are going to make of it.
- Should you have any doubt, refer to the dealer or ask an electrician.
- When connecting to the mains, follow the correct colour code for power cables: (N) blue, (L) brown or black and, only for class I equipment, (T) yellow/green.
- When lamps are to be fitted to the wall directly through their ceramic parts, fasten the fixing screws lightly, to avoid breaking the ceramic.
- To clean the lamp on the outside, use a soft cloth, possibly wet. Do not use solvents or abrasive products. No liquid must get in contact with the lamp interior parts.
- Do not touch the equipment with dirty hands.



= Class I equipment, must be connected to an earth terminal.



= Double insulated lamp, does not need earthing.



= Electrical equipment in class III, electrical safety guaranteed by low voltage tension, does not require grounding



= Replace immediately the safety glass, if damaged, with the original part.



= Minimum distance to be observed from all lit up objects.



= The lamp uses low pressure bulbs, and needs no protection glass.



= Device with CE marking



= The equipment at the end of its life must be collected separately from other waste